

Proper Installation of the REC HI-1500X

- Do not connect the power cord until the REC HI-1500X installation is complete.
 - Do not run the REC HI-1500X motor/pump assembly without water in the system or damage to the pump impeller may result.
 - Install the REC HI-1500X at an elevation below the water level of the system.
 - Ensure there is adequate ventilation and air circulation through and around the enclosure.
 - A 15Amp electrical power circuit equipped with a GFCI ground fault circuit interrupt is required for safe installation and operation of the REC HI-1500X.
1. The hose connections for the REC HI-1500X are labeled “IN” and “OUT.”
 2. Attach the hoses to the REC HI-1500X and securely tighten the hose clamps.
 3. Connect the first or “intake” hose to the REC HI-1500X port marked “IN”. This hose should pull from a low point in the system or from the bottom of the reservoir. This is the suction side and MUST be under water at all times when the unit is operating.
 4. Connect second or “discharge” hose to the REC HI-1500X port marked “OUT”. This is the pressure side of the pump and should be connected at a point on the system or reservoir, which is higher in elevation than the first hose.
 5. When all the connections have been securely tightened, fill the reservoir to the proper level with tempered water.
 6. Place the REC-HI-1500X at an elevation lower than the surface of the reservoir or jacket. and proceed to “prime” the pump.

Priming the Pump

1. Press the power switches on and off in short sequences until water is visible in the “IN” hose. When this occurs, leave the motor on only until a continuous flow of water is emerging from the “OUT” hose.
2. It may be necessary to roll the REC-HI-1500X from side to side to clear entrapped air in the system and prime the pump. If the air bubbled cannot be totally removed, check for loose connections, especially on the suction side of the system. You may be drawing air into the system.
3. Be certain that the hoses have no kinks. If your installation does not require the 6-foot lengths of hose supplied, then trim to length the hoses to avoid kinking.

Setting the Temperature of the System

1. Turn the “FINE” adjustment dial fully counter-clockwise to “zero”. Place the “COARSE” adjust dial to the mid-point, the system will hold a temperature of approximately 49°C (120°F).

2. Use a thermometer to check the temperature of the water jacket or reservoir. Rotate the “COARSE” adjustment dial to bring the temperature close to the desired temperature. The “FINE” adjustment dial will provide a precise adjustment allowing the system to hold temperature to an accuracy of +/- 0.25°C (0.50°F).

Safety - Power Cut - Off

Occasionally, during installation or operation, the controller can experience an over temperature condition, and the controller’s thermal overload switch will automatically cut-off power to the unit. If this occurs, turn the “COARSE” adjustment dial counter-clockwise to “0”. Let the unit cool down (approx. 30 minutes). The thermal overload switch will *automatically* reset itself. Then, simply reset the “COARSE” adjustment dial. The following checks should be made if the controller continues to overload or becomes inoperative.

Overload Condition

1. Check for kinked or collapsed hoses. See also “Priming the Pump”.
2. Is the REC HI-1500X at an elevation below the water jacket level?
3. Is the REC HI-1500X installed to allow circulation of air around the cabinet?

Non-Operative

1. Is the power switch on?
2. Check the building circuit breaker, the GFCI and the REC HI-1500X 15 Amp fuse.
3. Is the power cord plugged in?
4. If the unit is still inoperative after carefully checking all possibilities, return to RPR Zahn, LLC for repair.

Maintenance

All parts that are in immediate contact with water, including the pump and storage tank, are made of either stainless steel or inert plastic. However, for maximum life of the impeller housing, O-ring gasket, heater, and other operating parts, it is suggested that the water jacket be emptied at least once a week and flushed with clean water, including running fresh water through the pump system. This prevents build-up of calcium, chloride, and algae, which will eventually cause failure of the pump seals. Hard water containing iron and other minerals will cause early failure to the heater element. Filter the main water supply.

Lubrication

The recirculating pump must be oiled at least once every 6 months. Use a light machine oil product. Place several drops in the front and rear motor bearings.

RPR ZAHN ELECTRONICS

Instruction and Operating Manual for REC HI-1500X Water Recirculation System

The REC-HI-1500X Water Heater Recirculation System is designed to recirculate water. Before using this product with other liquids; first consult with the RPR Zahn Technical Support team. The system is designed as a temperature control and re-circulation device for closed-loop systems or open reservoirs. This product is not designed to operate under pressure and should not be attached to building, plant or other pressurized systems.

The REC-HI-1500 system is intended to maintain a process temperature between 24°C (75°F) and 80°C (175°F). As the system heats the water the solid-state temperature controller, using feedback from a thermistor will maintain the reservoir temperature to an accuracy of +/- ¼°C, (½ °F).

RPR Zahn Electronics Model Number: REC HI-1500X Specifications			
Input Power:	14.0 Amp	Temp Cut Off:	87°C (190°F)
Input Voltage:	120VAC @ 60HZ	Fuse Type:	15A-ABC Slow Blow
Heating Power	1500 Watts	Pump Capacity:	30Liter/min.
Heating Rate:	1.0°C/Liter/min.	Pump Capacity:	8.0 gal./min.
Heating Rate:	7.0°F/Gal./min.		

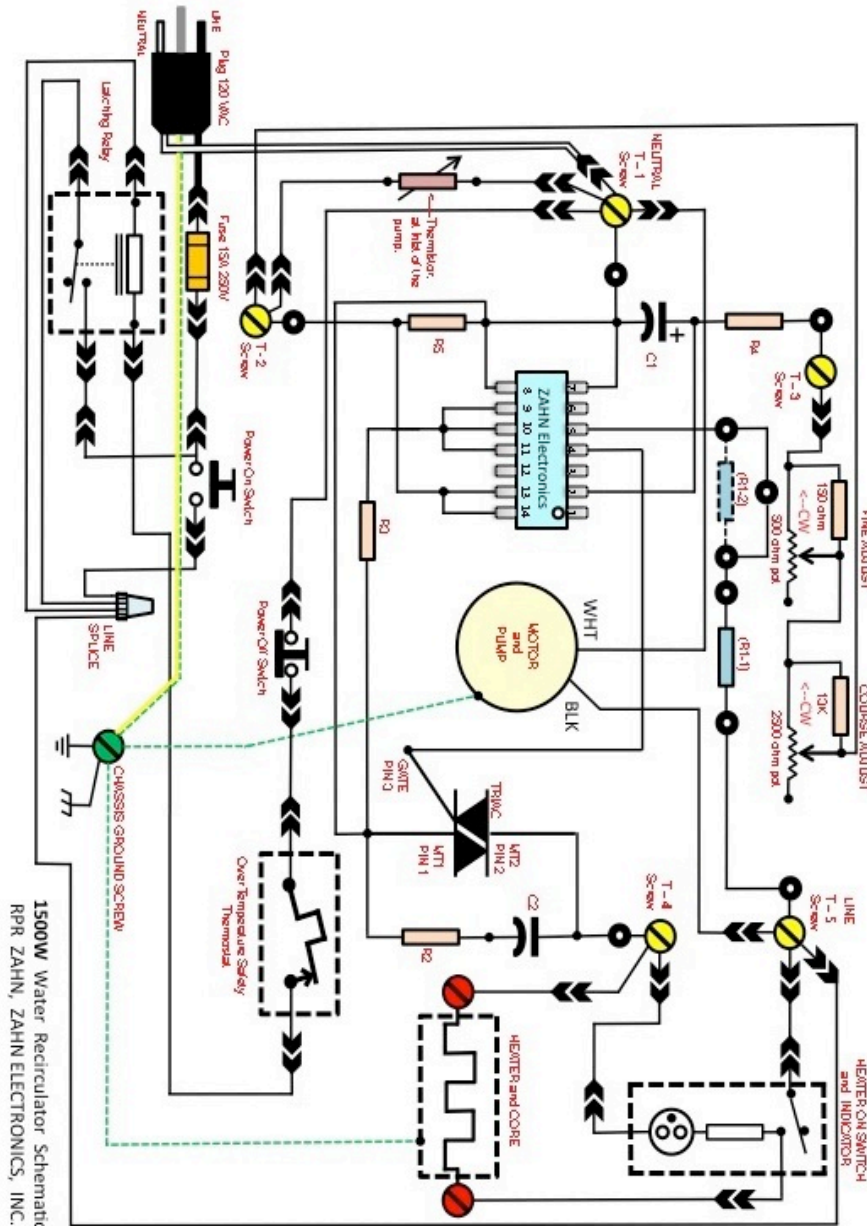

1500W Water Recirculator Schematic
RPR ZAHN, ZAHN ELECTRONICS, INC.

4133 Courtney St., #5, Franksville, WI 53126, USA
www.zahninc.com www.rprcorp.com 262.835.9200